

SYSTEM OVERVIEW

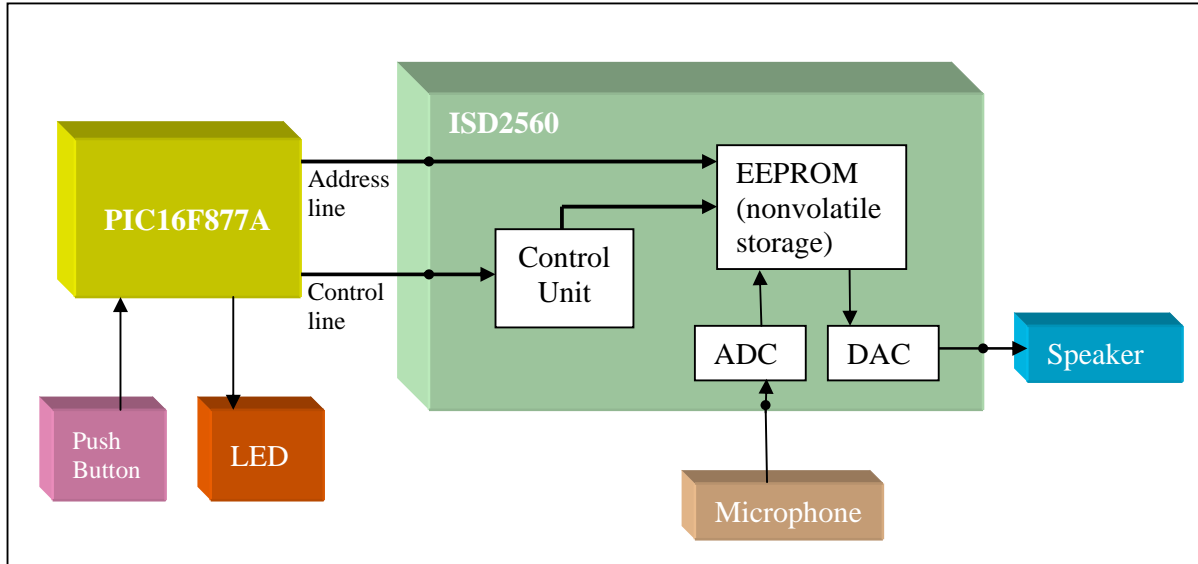

GENERAL DESCRIPTION

When we talk about voice recording, the first thing that comes to our mind is an old cassette player where we record voice, and playback the recorded voice.

ISD2560



Figure 1

Winbond’s ISD2560 ChipCorder Series provides high-quality, single-chip, Record/Playback solutions for 60 second messaging applications. The CMOS devices include an on-chip oscillator, microphone preamplifier, automatic gain control, antialiasing filter, smoothing filter, speaker amplifier, and high density multi-level storage array. In addition, the ISD2560 is microcontroller compatible, allowing complex messaging and addressing to be achieved. Recordings are stored into on-chip nonvolatile memory cells, providing zero-power message storage. Voice and audio signals are stored directly into memory in their natural form, providing high-quality, solid-state voice reproduction.

PIC16F877A

This powerful (200 nanosecond instruction execution) yet easy-to-program (only 35 single word instructions) CMOS FLASH-based 8-bit microcontroller packs Microchip’s powerful PIC® architecture into an 40- or 44-pin package and is upwards compatible with the PIC16C5X, PIC12CXXX and PIC16C7X devices. Features of the device:

- 256 bytes of EEPROM data memory
- self programming
- ICD (in circuit debugging function)
- 2 Comparators
- 8 channels of 10-bit Analog-to-Digital (A/D) converter
- 2 capture/compare/PWM functions
- synchronous serial port can be configured as either 3-wire Serial Peripheral Interface (SPI™) or the 2-wire Inter-Integrated Circuit (I²C™) bus
- Universal Asynchronous Receiver Transmitter (UART).

All of these features make it ideal for more advanced level A/D applications in automotive, industrial, appliances and consumer applications.

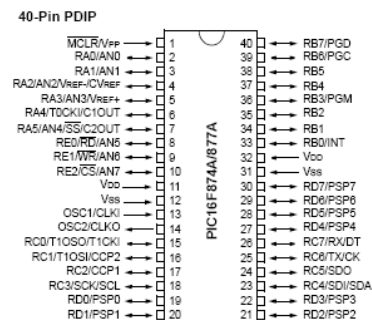

Figure 2

Figure 2 shows the pin diagram for PIC16F877A. For more information about the PIC microcontroller, please refer to the datasheet. The datasheet can be found in microchip web site at: <http://www.microchip.com>

HARDWARE

This project will require following hardware:

- 1 x PIC16F877A
- 1 x PR17 Printed Circuit Board (PCB)
- 1 x ISD2560
- Related electronic components

Please refer to Appendix A for the PCB layout of PR17. The PCB layout is provided free therefore Cytron Technologies will not be responsible for any further modification or improvement.

Interface PIC16F877A with ISD2560

Pin	Name	Pin function	Connection
1	AN0	Address pin 0	RD0
2	AN1	Address pin 1	RD1
3	AN2	Address pin 2	RD2
4	AN3	Address pin 3	RD3
5	AN4	Address pin 4	RD4
6	AN5	Address pin 5	RD5
7	AN6	Address pin 6	RD6
8	AN7	Address pin 7	RD7
9	AN8	Address pin 8	RC4
10	AN9	Address pin 9	RC5
23	CE	Chip Enable (low to enable device operation)	RC0
24	PD	Power Down (high to place device in standby mode)	RC1
27	P/R	Playback/Record	RC3
25	EOM	End-Of-Message (pulse low at the end of each message)	RC2
22	OVF	Overflow (pulse low at the end of memory array)	RE0
28	VCCD	Supply voltage (digital)	Connected to 5V
16	VCCA	Supply voltage (analog)	Connected to 5V
12	VSSD	Ground (digital)	Connected to GND
13	VSSA	Ground (analog)	Connected to GND

Table 1

*For more information about pin that is not shown in the table 1, please refer to ISD2560 datasheet.

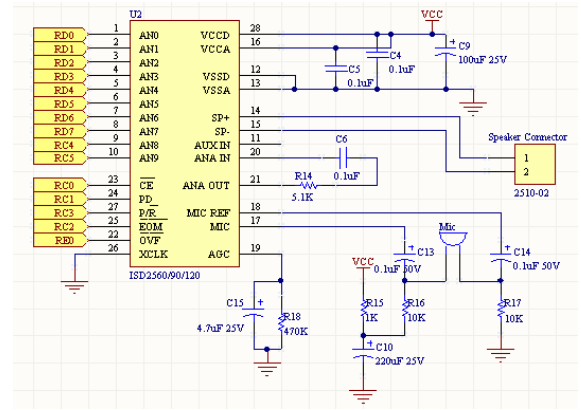

Figure 3

Power supply for the circuit

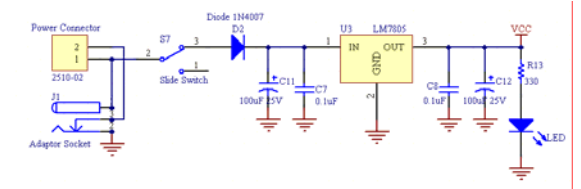

Figure 4

User can choose either AC to DC adaptor (not included in the DIY project set) or 9V-12V battery (not included in the DIY project set) to power up the circuit. Higher input voltage will produce more heat at LM7805 voltage regulator. Typical voltage is 12V. Anyhow, LM7805 will still generate some heat at 12V. There are two type of power connector for the circuit, DC plug (J1) and 2510-02 (Power Connector). Normally AC to DC adaptor can be plugged to J1 type connector.

Refer to Figure 4, the D2 is use to protect the circuit from wrong polarity supply. C7 and C11 is use to stabilize the voltage at the input side of the LM7805 voltage regulator, while the C8 and C12 is use to stabilize the voltage at the output side of the LM7805 voltage supply. LED is a green LED to indicate the power status of the circuit. R13 is resistor to protect LED from over current that will burn the LED.

Push Button as input for PIC microcontroller

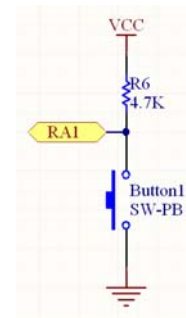

Figure 5

One I/O pin is needed for one push button as input of PIC microcontroller. The connection of the push button to the I/O pin is shown in Figure 5. The I/O pin should be pull up to 5V using a resistor (with value range 1K-10K) and this configuration will result an active-low input. When the button is being pressed, reading of I/O pin will be in logic 0, while when the button is not pressed, reading of that I/O pin will be logic 1.

LED as output for PIC microcontroller

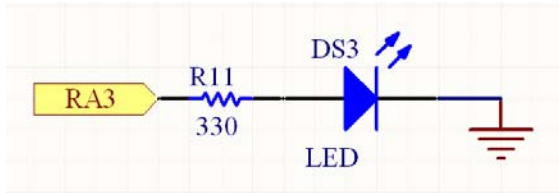

Figure 6

One I/O pin is needed for one LED as output of PIC microcontroller. The connection for a LED to I/O pin is shown in Figure 6. The function of R11 is to protect the LED from over current that will burn the LED. When the output is in logic 1, the LED will ON, while when the output is in logic 0, the LED will OFF.

ICSP for programming PIC microcontroller

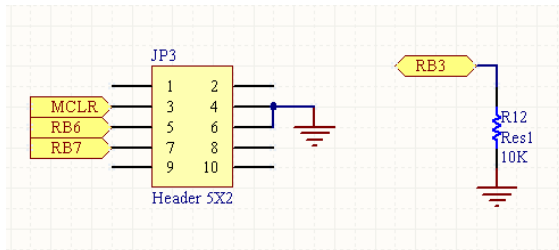

Figure 7

MCLR, RB6 and RB7 need to be connected to the USB In Circuit Programmer (UIC00A) to program the PIC microcontroller. At the same time, RB3 need to be pull low to 0V to disable low voltage programming, because the programmer is using high voltage programming. The programmer (UIC00A) is not included in DIY project set since it can be used several time for different project set. User can also choose other type of PIC programmer to load the program.

For the instruction of using PIC programmer, please refer to the particular PIC programmer user's manual.

PCB circuit board

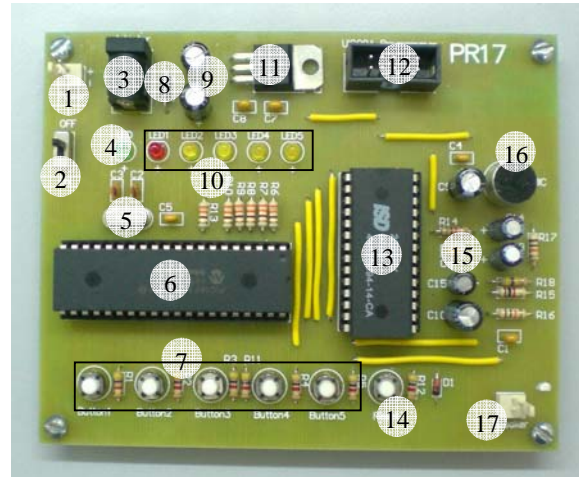

Figure 8

Component:

1. 2510-02 connector, (to use either 9V battery or 12V battery to power up the circuit).
2. Slide switch (to ON or OFF the circuit).
3. AC-DC adaptor socket (to use power supply from AC-DC adaptor).
4. Power indicator LED (to indicate the power status of the circuit).
5. Crystal (20MHz).
6. PIC 16F877A (the main brain of the system).
7. Push button.
8. Diode (to protect the circuit from wrong polarity power input).
9. Capacitor (to stabilize the output voltage of the 7805 voltage regulator).
10. LED.
11. LM7805 (voltage regulator, supply 5V for PIC).
12. ICSP box header (to connect to PIC programmer to program the microcontroller).
13. ISD2560 (chip to record and playback voice).
14. Reset button (to reset the microcontroller).
15. ISD2560 support component.
16. Microphone (to record voice).
17. 2510-02 connector, (to connect to an external speaker).

SOFTWARE

Flow Chart:

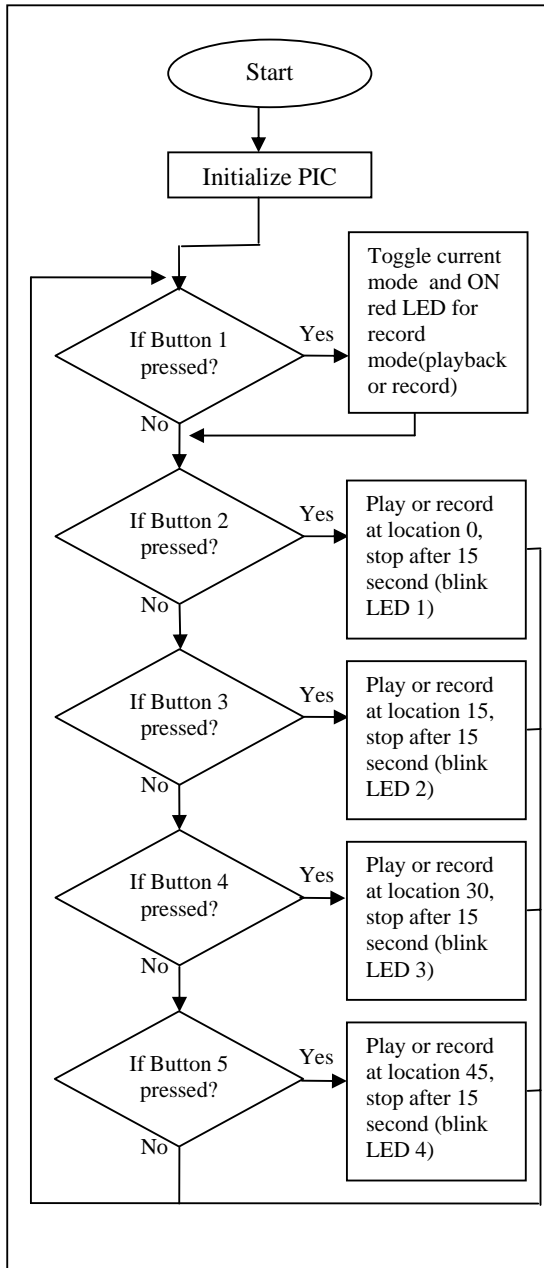

For more information about the software for this system, please refer to the source code provided. The explanation of each instruction is provided in the source code as the comment of each line.

The source code is provided free and Cytron Technologies will not be responsible for any further modification or improvement.

GETTING START

User can obtain the hardware set for this project (PR17) either by online purchasing (www.cytron.com.my) or purchase it in Cytron Technologies Shop.

1. Once user has the hardware set, soldering process can be started. Please solder the electronic components one by one according the symbols or overlays on the Printed Circuit Board (PCB). Ensure the component value and polarity is correctly soldered. Please refer to PCB Layout in Appendix A.

Caution: Make sure all the connectors (2510) are soldered in proper side. Those electronic components have polarity such as capacitor, diode, PIC, LM7805 and LED should be soldered in right polarity or it may cause the circuit board fail to work.

Warning: Before the battery (Power) is plugged in, make sure the polarity is correct to prevent the explosion. Wrong polarity of capacitor also may cause explosion.

2. Please download the necessary files and document from Cytron Technologies website. These included documentation, sample source code, schematic, component list and software.
3. The next step is to install MPLAB IDE and PICC Lite into a computer. The MPLAB IDE and PICC Lite can be downloaded from www.cytron.com.my.
4. After the installation complete, open the project file provided using MPLAB IDE. Please refer to PR1 and PR5 for the method to use MPLAB and PICC Lite.
5. Plug in power supply for the circuit. User can choose to use battery or AD to DC adaptor.

AC to DC adaptor:



Figure 9 (not included in DIY project set)

9V battery connector:

Figure 10 (not included in DIY project set)

Connection to the PCB board:

Figure 11

6. Build the project and load the hex file into the PIC microcontroller using USB In Circuit Programmer (UIC00A).
7. Press button 1, LED red will turn ON. Press button 2 LED 2 (Yellow LED) will blinking and ready to record.
8. After 15 second, press button 1, Red LED will turn OFF and press button 2 to playback
9. Modify the program.
10. Have fun!

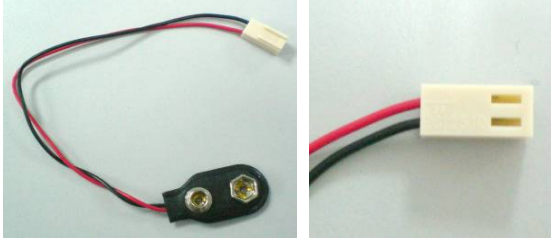
WARRANTY

No warranty will be provided as this is DIY project. Thus, user is advice to check the polarity of each electronic component before soldering it to board.

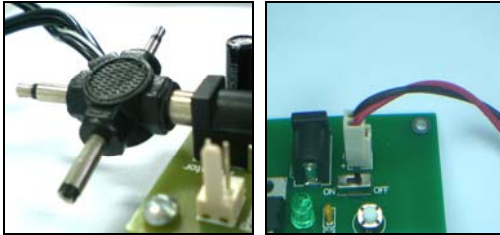